

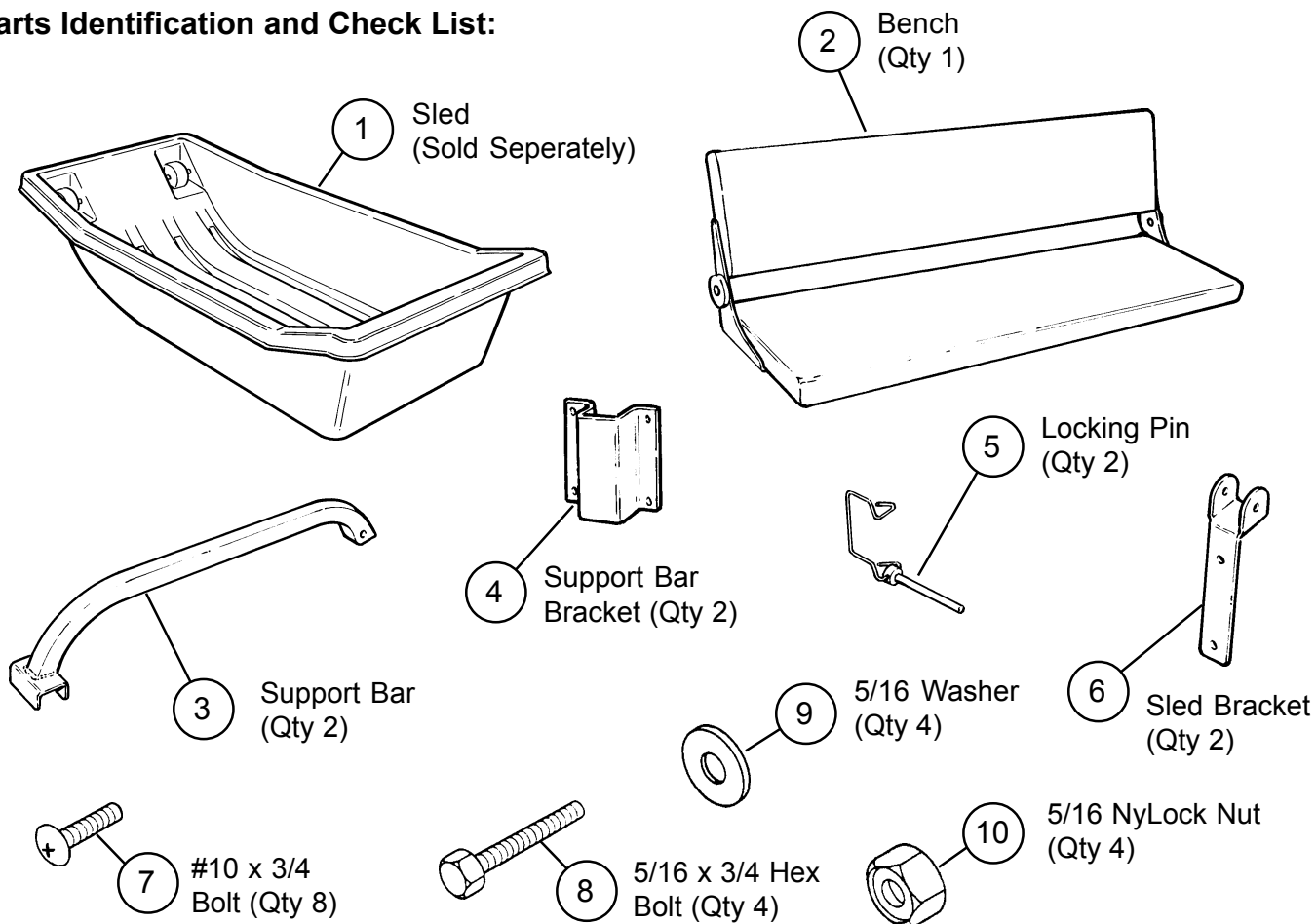

Otter II Bench Option Installation and Set-Up Instructions

Parts Identification and Check List:



Tools Required:

1/2 Box End Wrench
1/2 Socket and Ratchet
Drill
3/8 Bit
Phillips Screwdriver

Installation:

1. Layout all parts.
2. Attach both support bars (Item 3) to the bottom of the bench (Item 2) with the support brackets (Item 4). Attach the support brackets using the #10 x 3/4 bolts (Item 7) into the predrilled holes in the bench. Ref. Diagram 1.

Diagram 1

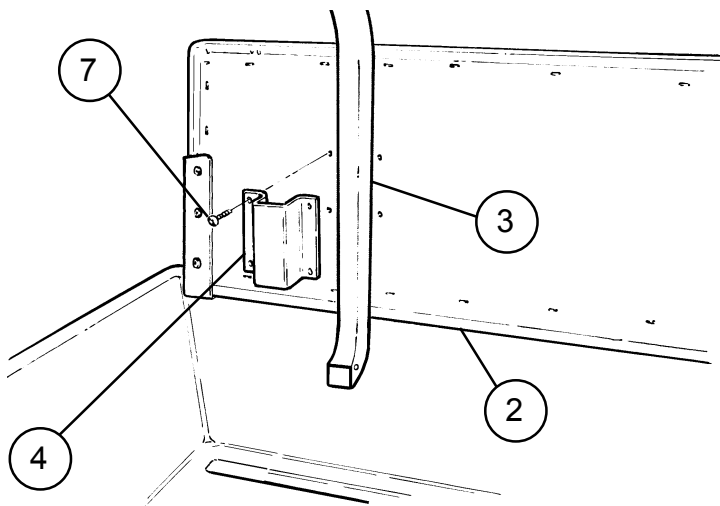

3. Place the bench seat assembly onto the sled and set to desired position.
4. Slide the sled bracket (Item 6) under the bench seat assembly and on top of the sled (Item 1) lip. Mark the holes to be drilled and drill two 3/8 in. holes.
5. Measure the specified distance (**See Note 1**) over and attach the second sled bracket (Item 6) by marking the holes to be drilled and drill two 3/8 in. holes.
6. Attach the sled brackets (Item 6) to the sled (Item 1) using a 5/16 x 3/4 bolt (Item 8), 5/16 NyLock nut (Item 10) and 5/16 washer (Item 9).
7. Take the bench assembly and place the hinged end of the support bracket (Item 3) into the sled bracket (Item 6).
8. Insert the locking pin (Item 5) and secure the bench assembly to the sled (Item 1).

Diagram 2

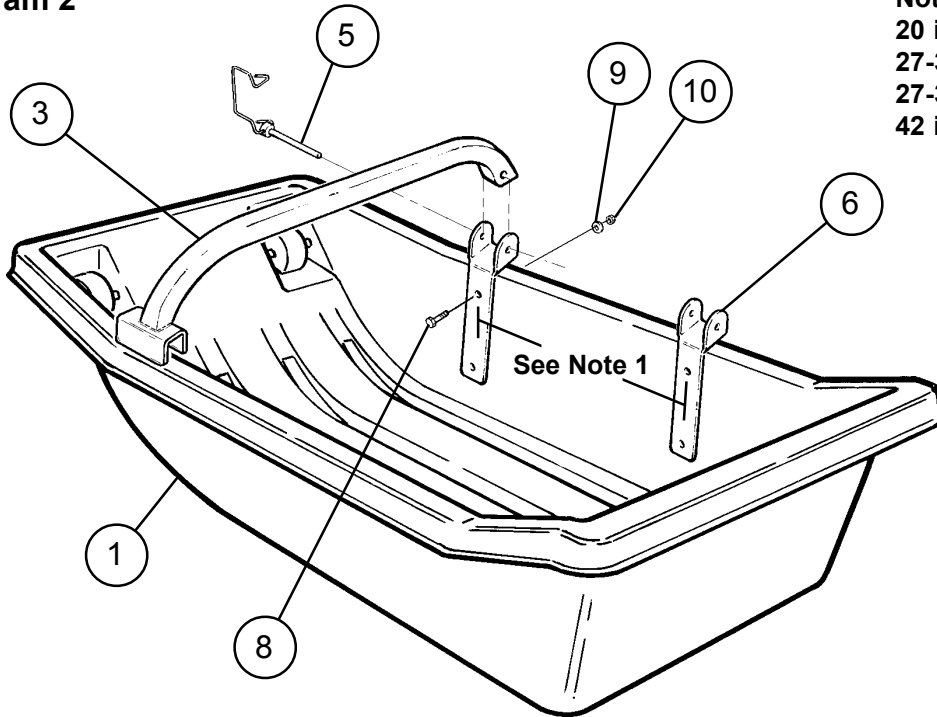

Note 1:

20 in. Small Sled
 27-3/4 in. Medium Sled
 27-3/4 in. Magnum Sled
 42 in. Large Sled

9. Once mounted the bench can open and close to gain access to the inside of the sled.

Diagram 3

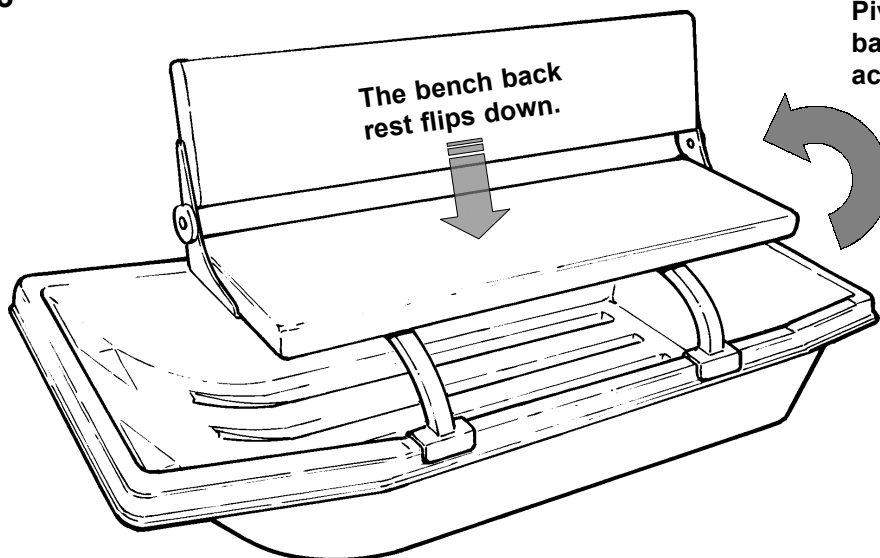

Bench Option
 September, 2003